

THE NATIONAL FOUNDATION FOR FACIAL RECONSTRUCTION

MY FACE

THE NEW NFFR MAGAZINE

KIRAN'S
TELEVISION
DEBUT!

INSIDE!

INSPIRATIONAL FAMILY
STORIES OF
LOVE & COURAGE

+

NUTRITION ADVICE
FROM OUR VERY OWN
DEBORAH MALKOFF

+

HOW TO GET INVOLVED...
& SO MUCH MORE!

**FRESH
FACES**

WELCOMING

THE NEW
NFFR FAMILY

+

EXCLUSIVE
DISCO FOR MEDICINE
&
RACES FOR FACES PHOTOS
INSIDE!

FALL/WINTER 2013

Photo by Mary Spano

MY FACE

letter from the NFFR's



Photo by Mary Spano

new E.D.

STRENGTH, COURAGE, BRAVERY and RESILIENCE.

These are the words that come to mind while I observe the weekly patient conferences at the Institute of Reconstructive Plastic Surgery. The interdisciplinary team of doctors from NYU Langone Medical Center and the team of professionals from the Newman Family Support Center greet, comfort, examine and treat each family with compassion and understanding. The families are at varying stages, some expecting a baby with a cleft lip, some with children who have had ten surgeries

and need twenty more and others nearing the final surgery with their teenage child. Regardless of where the family is in their process, they all exemplify incredible strength, courage, bravery and resilience. There are so many challenges involved with raising a child with a facial difference yet these families exude gratitude, compassion and comfort. The relationship between the families and the professionals is beautiful and warm. All questions are answered in depth and a careful plan is formulated for each child.

I am truly honored and privileged to have been recently appointed Executive Director of the National Foundation for Facial Reconstruction and look forward to enhancing current programs and creating new initiatives to enable our patients and their families to thrive. I am also very proud to have a phenomenal new team join me, all of whom are featured in this newsletter. We have lots of exciting new plans for the NFFR and welcome you to join us! We have created a Young Professional Board that will host an amazing pre-Super Bowl party on January 30th and we have secured the Central Park Zoo for our annual gala on May 15th. Last but not least we hope that you will join us in November at Saks Fifth Avenue for our first annual holiday shopping extravaganza. I am looking forward to giving the NFFR a new look and feel and always welcome your suggestions and feedback. I hope to meet many of you at our upcoming events and greatly appreciate your ongoing support.

WITH WARM REGARDS,

Carolyn Spector

CAROLYN SPECTOR, J.D., LL.M.

Executive Director



I am thrilled to be the newly appointed Executive Director of the National Foundation for Facial Reconstruction. I am truly excited about enhancing NFFR's organizational vision, developing innovative programs and securing the resources to ensure the achievement of NFFR's short and long-term objectives.

Most recently, I served as the Executive Director of Mission: Restore, a Foundation that provides life-saving and life-changing reconstructive surgery both globally and locally to children and adults in need. I also served as Deputy Director of the Criminal Justice Division of Safe Horizon, the nation's largest provider of services to victims of crime, where I was responsible for the daily operation of more than thirty crime victim programs located throughout the five boroughs.

Prior to moving to New York City, I held the position of Assistant District Attorney in the Middlesex County District Attorney's Office, in Cambridge, Massachusetts. I was also a Visiting Professor at Northeastern University's Graduate School of Criminal Justice.

I have my Juris Doctorate from Boston University School of Law, a Masters in Science degree from Northeastern University's Graduate School of Criminal Justice, as well as an LL.M. in criminal law and constitutional law from New York University Law School.



ERIN JOHNSON
Director of Development

As the new Director of Development, I plan to increase awareness of the NFFR and grow our donor base by showcasing the heart and soul of the organization that helps so many individuals overcome the challenges of having a facial difference so that they can live, laugh and love with pure abandon. There is an incredible aura of hope both at the IRPS and the NFFR that emanates from everyone I come into contact, be it the patients, their families, the surgeons, the staff and our donors. I have always thrived on being a passionate champion for causes I believe in and the NFFR makes it so easy to be a champion each and every day.



KIR SELERT
Development & Events Manager

For the first time, I feel connected to and impassioned by my work. In the short time since leaving academia, the void I felt in neuroscience research has been filled by the family and friends of NFFR. My goal of making a meaningful difference in the lives of others no longer feels like a distant cliché. I'm humbled to be surrounded by such resilient and awe-inspiring individuals and excited for the opportunity to work hard for their benefit.

Meet the New
NFFR
Family

Photos by Saulo Villela

SAULO VILLELA PR & Branding Specialist



Since a young age, I have been fascinated by fine art, architecture, and fashion. After meeting Carolyn and the amazing staff of the NFFR & IRPS, my creative juices began to flow like never before and a new inspiration ignited in my soul. I was captivated by the mission of the NFFR & IRPS and all the passion and hard work that goes into restoring the lives of those with facial differences. I am honored and thrilled to be a part of such a noble mission.

DINA ZUCKERBERG Family Program Director



NFFR's mission reflects my passion and my passion reflects the mission. I feel I can bring my life experience of growing up with a facial difference to the programs I help implement for our families and the people I help educate. I truly believe we can make a difference in their lives and I'm thrilled to be a part of the NFFR family.

EDDIE PLATA TALKS ABOUT HIS EXPERIENCE AT THE NFFR

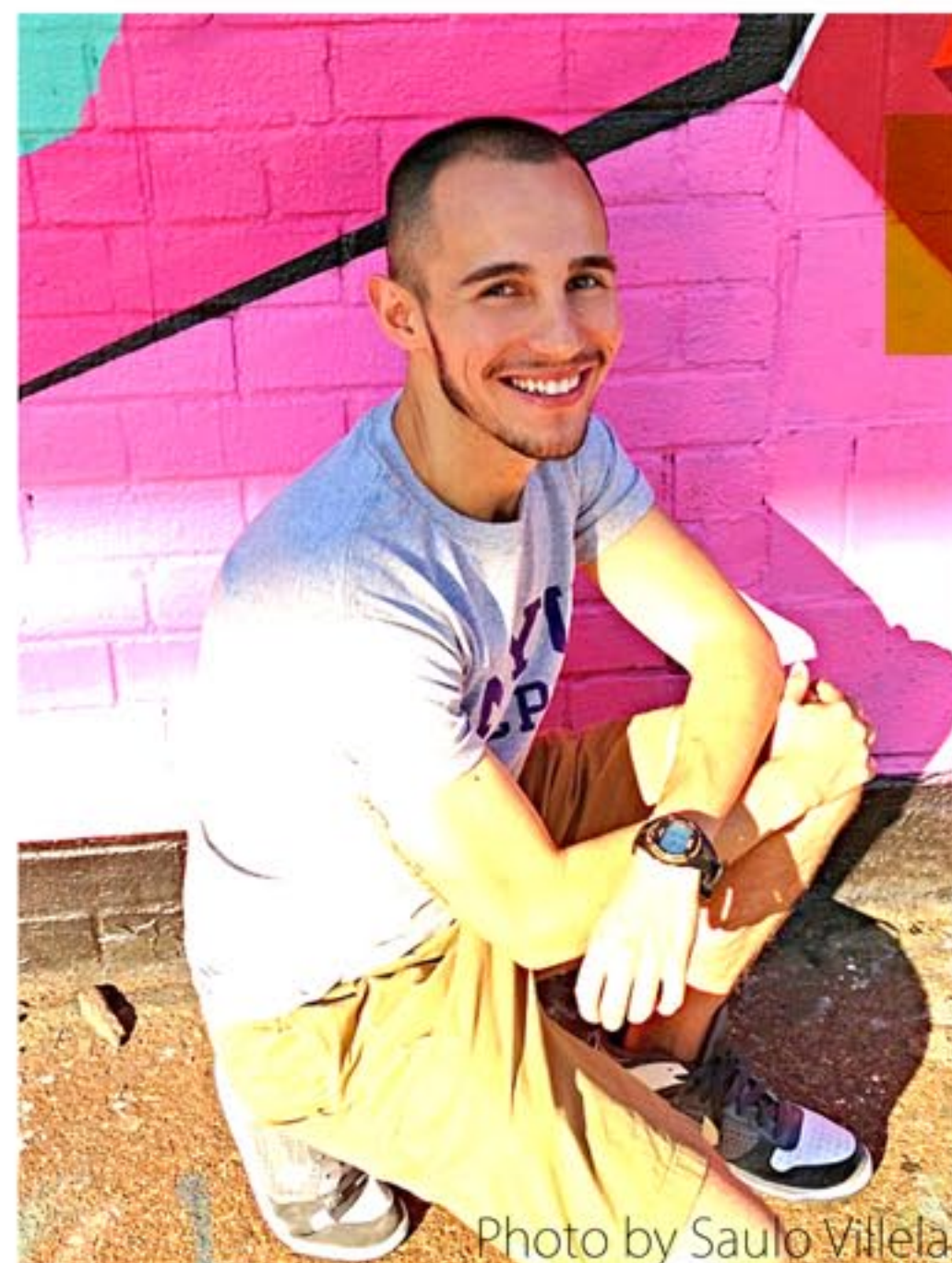

Photo by Saulo Villela

The NFFR relies on the kindness of our volunteers who dedicate their time and compassion each week to ensure the smooth-running of all facets of the NFFR, including office logistics, community outreach, fundraising events, and family support programs.

Meet Eddie, NFFR volunteer and office manager extraordinaire who appeared all the way from Miami to help organize and orchestrate NFFR office affairs.

What has been your most rewarding and meaningful moment since coming to the NFFR?
Definitely the Races for Faces event. Spreading the word about the organization to the general public and talking about our mission to serve the needs of children and adults with facial differences is something that will always stick to my heart.

What keeps you coming back 9-5, Monday/Wednesday/Friday?
The families and patients who visit the office of course! I'm inspired by the stories I read daily about the struggles that these children/adults go through and the strength they exude as individuals.

What would you tell others interested in volunteering?
It's beyond rewarding to be part of such a great cause and to interact with families and patients who have benefited from the NFFR's mission. Most recently, I read about Damian Lopez Alfonso, an inspiring athlete who doesn't let his disfiguring injuries sustained in childhood impede upon his dreams of professional cycling. Damian says it well here: "Life for me is a race: every day that goes by is a day that is lost, and that day never comes back." Each day that I come to volunteer and see firsthand the work of the NFFR is time won, not lost.

What led you to the doors of the NFFR?
I came across the NFFR website and found myself interested in learning more about the organization and how a facial difference impacts a person's life from infancy to adulthood. The amount of surgeries that one must go through and the courage that these patients have is incredible.

What's NEW AT the IRPS?

THE IRPS CENTERS OF EXCELLENCE

Since its grand opening on January 24, 2013, the new Institute of Reconstructive Plastic Surgery (IRPS) has grown to include 15 Centers of Excellence. Each Center of Excellence is comprised of representatives from all required specialties, who meet regularly to evaluate new and former patients with complex problems and formulate comprehensive treatment programs.

For further information on the specific Centers, visit: www.plastic-surgery.med.nyu.edu/patient-care

- The IRPS Centers of Excellence include:
- Aesthetic Surgery Center
 - Airway Center
 - Breast Plastic Surgery Center
 - Cleft Lip and Palate Center
 - Craniofacial Center - Adult and Head & Neck
 - Craniofacial Center - Pediatric
 - Craniofacial Dental Center
 - Hand Surgery Center
 - Hemangioma and Vascular Malformations Center
 - Microtia and Ear Anomaly Center
 - Nerve Center
 - Newman Family Support Center
 - Oculoplastic Surgery Center
 - Photography and Biodigital Imaging Center
 - Wound Healing Center

HOW TO EAT RIGHT

Deborah A. Malkoff MS, RD CDN



Photo by Mary Spano

OUR OWN DEBORAH MALKOFF FILLS US IN

Why is nutrition counseling such a vital part of the Newman Family Support Programs?

Post-surgically, eating and chewing are both compromised in many of our patients, and meeting their calorie and protein needs is our main goal to optimize healing. Some patients may be on a liquid diet for more than 8 weeks, so ensuring the patient has different options is KEY to avoid extreme boredom and burnout!

What is the most fulfilling and enjoyable part of your work?

I LOVE the team here at the IRPS. Everyone is so knowledgeable and we work as a family to give support, education, and a one-stop-shop for the families. The patients are amazing here; everyone has a different story to tell and I work with each patient individually to devise a "menu" that is appealing to them as they progress from the clear liquid diet -> full liquid -> puree diet -> soft solids. My favorite was an 8-year-old boy asking me if he could blend a hamburger to put through the squeeze bottle during the puree-phase. My response, "As long as it is a pudding consistency and can fit through the straw, rock on!"

How do you ensure that the children receive proper nutrition surrounding facial reconstruction?

Sometimes it is necessary to rely on supplementation like PediaSure or Ensure which both supply 240-250 calories and ~7 grams of protein per 8 ounces. But, ultimately the best option is always to make homemade smoothies, which contain less preservatives, and add calorie and nutrient dense ingredients. This allows for patients to customize meals based on their likes and dislikes. High calorie additives can be avocado (1/2 = 130 calories), heavy cream (1 tablespoon = 50 calories), and/or flaxseed oil (1 tablespoon = 120 calories) and various protein powders can be added to help boost daily protein intake.

How often are permanent feeding tubes necessary to provide adequate nutrients?

I try to avoid feeding tubes at all costs. If a patient was eating prior to surgery, he should be able to eat some form of food/liquid post-operatively. This is where the team approach comes in. I partner up with our speech therapist, Shelley, to make sure choking/aspiration is not an issue. If it's not, I would suggest an oral supplement like PediaSure since it is convenient and readily made, calorie dense and kids seem to like it.

How are the nutrient needs different for a child/individual going through facial reconstruction?

I base the calorie and protein needs on the individual patient's age, height, weight, and prior activity level. We discuss food allergies and cultural/religious food preferences as well. My relationship with every patient is mutual: I love getting their feedback and ideas to incorporate in my dietary advice.

What additional programs and resources would you like to introduce to The Newman Family Support Team?

I am currently working on a grant with the NFFR to rewrite the "Healing Jaw" book. My goal for the updated version is to have my patients submit favorite recipes (full liquid, puree diet, etc.) that worked in their recovery and to give them credit in the book. Each recipe will also be analyzed to show its calorie, protein and fat content so patients and families will be able to keep track of daily intake easier.

Do you have a specific motto you like to share with families or few dietary words to live by?

Moderation, moderation, moderation!

What food/ meal would you never want to live without?

Italian and dessert! Moderation.

MEET THE GRANTS

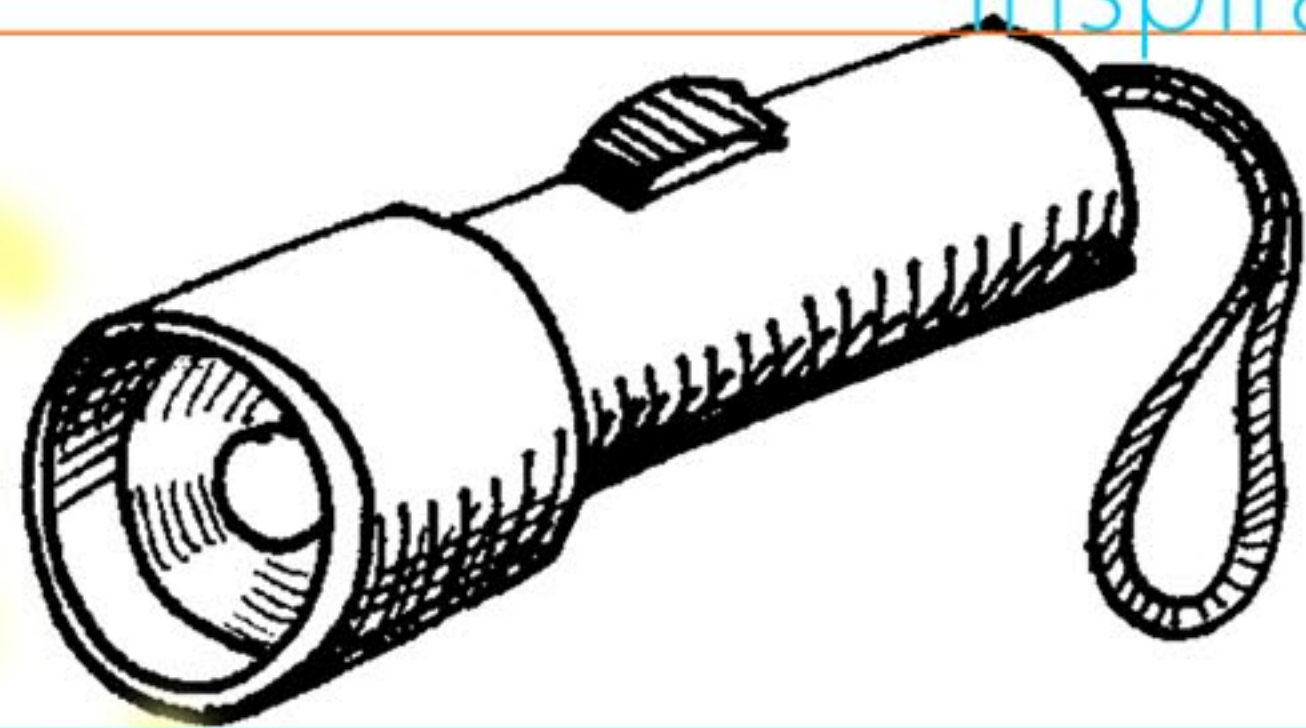

A Story about love, courage, faith... and a beautiful little boy named Sammy

W

hen I was 18 weeks pregnant, I discovered at a routine gender scan that my little boy was going to be born with a cleft lip. I was in shock, and the only thing I could think of was that my precious baby was going to have surgery. The doctor's office had no materials or information for me. The doctor simply stated that there was a really good plastic surgeon in Charlotte, NC close to where we live and that I needed to meet with him before the baby was born. I called the plastic surgeon's office the next day, but they never called me back. In the meantime, I conducted tons of research and one evening I came across some absolutely amazing before and after pictures. When I clicked on the site, I was looking directly at Dr. Court Cutting! I read all about the NAM and I called the office the next day to make a prenatal appointment with the Cleft Team and off to New York we went. My family thought that I had lost it. Could I really fly to NY every week with a newborn baby? How would we ever afford it? What would I do with my other baby? However, after we met the NYU Cleft Team, there was no turning back.

Traveling to NY every week had its ups and downs. We would wake up at 3:30am, catch the 6am flight out of Charlotte, and meet with Dr. Grayson for Sammy's NAM at 10am. Then we would head back at about 3pm to be home by 8pm. I learned so much about humanity during this time. Soon, I looked forward to traveling with Sammy, spending all day snuggling with him, and talking to my new friends at the NFFR and IRPS.

Samuel had his lip repair by Dr. Cutting on October 23, 2012. Samuel had a difficult time breathing after his lip repair and had to be rushed back to the ER. The night of our discharge, my husband and I watched out the window as Hurricane Sandy hit NYC. Our hotel lost power, which was a nightmare. Samuel was on continuous feedings by his feeding pump which requires electricity. I sat in the hotel lobby to charge Sammy's pump every couple of hours.

I began to worry about the removal of Samuel's stitches because I wasn't sure if Dr. Cutting was going to be able to get into the city. To minimize scarring, it is important to get them out after 12 or so days. Dr. Cutting reassured me that he would find a way to the city and we would remove Sammy's stitches with or without power. We waited for him in a dark, empty building as people were flushing water out of it with hoses. Using flashlights and our cell phones as illumination, we found our way to his office. We agreed that the best way to take out his stitches was to place Sammy on the windowsill, and open the curtains to get as much sunlight as possible. We all held up flashlights and used our phones to provide maximal lighting. Dr. Cutting's wife was even holding a flashlight! Sammy's stitches came out beautifully thanks to Dr. Cutting's wonderful job! Of course we were stuck in NY for several more days due to our flight being canceled over and over. Boy, we were so happy when we landed back in Charlotte! It was dry, sunny and just beautiful!!

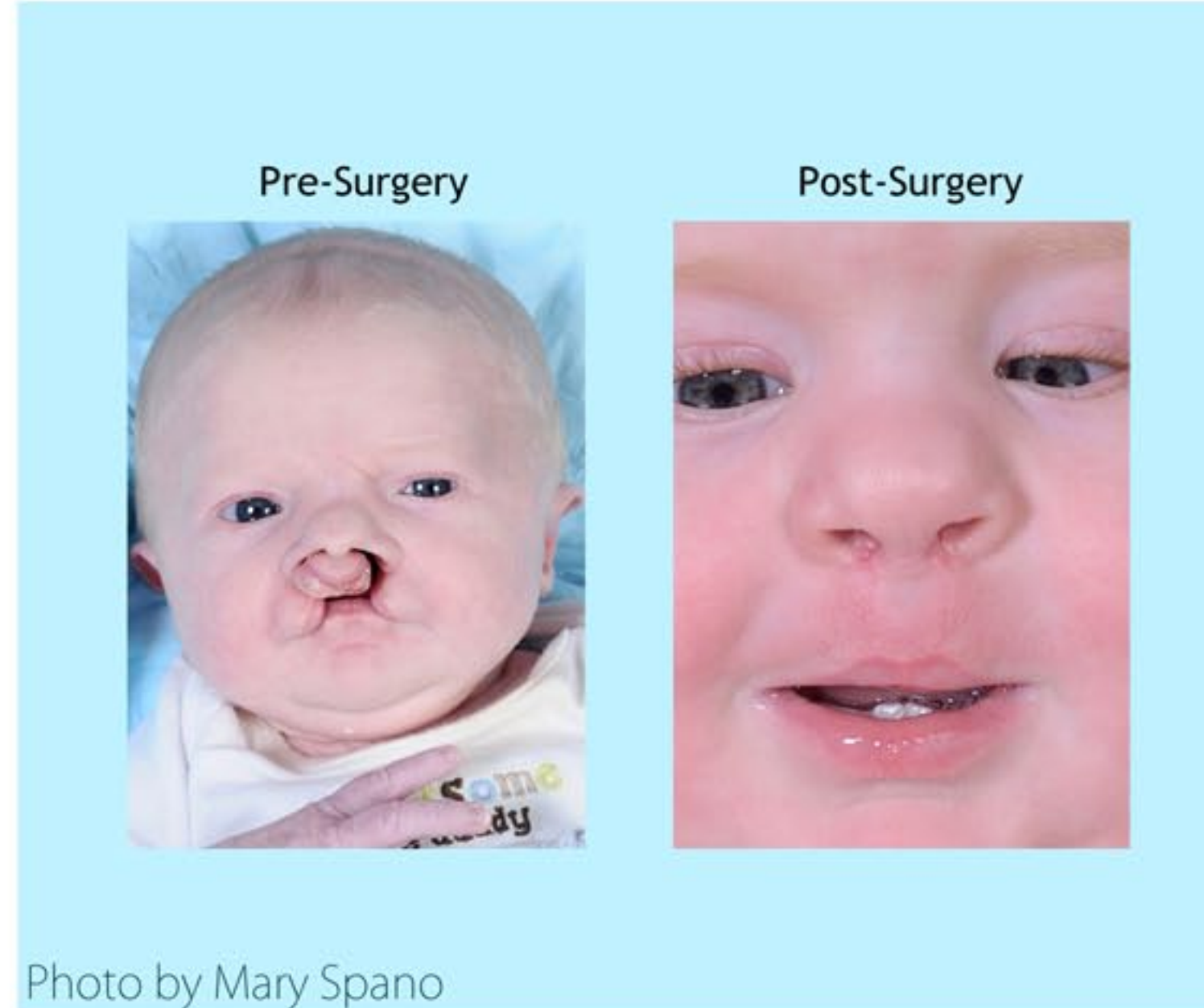

Photo by Mary Spano

When I was pregnant with Sammy, we were fortunate to stay in the NFFR apartment during our prenatal consultation in NY. I vividly remember reading about other's stories in the guestbook. My heart was heavy for the other children who suffered long surgeries and recoveries. However, reading about their journeys gave me the strength I needed to get through the very difficult emotional time. I knew that if they could do it, then I could do it. These children have helped make my family so strong and more loving than ever before. We now value life on a whole different level. We know that each day is a blessing. Although some days are harder than others, I know I can get through it with the help and inspiration of the NFFR family and all of the strong children the NFFR supports.

When we were planning Samuel's first birthday party, I wanted to do something special for an organization that is so close and dear to my heart. What better way to celebrate Sammy's beautiful life than to donate to a charity that made it all possible? I truly believe that we would not be where we are today if we were not part of the NFFR family. I designed Samuel a first birthday card to send to all of our friends and relatives. On the back I had this message printed: "I cannot thank everyone enough who belongs to the NFFR for all of their love and support. We would not be where we are today without the support from the NFFR." Sammy's first birthday raised \$375 for the NFFR.

Our lives have changed tremendously since becoming part of the NFFR family. They have taught me what it means to love unconditionally. They looked past Samuel's birth defect and saw Sammy for the beautiful, amazing baby that he is. They taught me to accept the perfect little boy that God blessed us with. - Melony Grant

the In News



Kiran's Television Debut!
The Fernando Family recently shared their incredible story with Amy Freeze from ABC Channel 7 Eyewitness News to inform people of the struggles and prevailing strength of children and adults born with a facial difference and the families who stand behind them. Born with Goldenhar Syndrome, Kiran is now a lively and thriving four year-old thanks to the life-changing work of the IRPS and funding from the NFFR. Visit our Facebook page for the complete news coverage and to read Dana Fernando's eloquent speech from Races for Faces 2013.

A heartfelt thank you to Amy Freeze & ABC Channel 7 Eyewitness News and the Fernando Family for sharing one of the NFFR's beautiful family stories.



The Posadas' Home Run for NFFR!

In April, former New York Yankee Jorge Posada and his wife, TV life coach and philanthropist Laura Posada, invited several IRPS patients to a special pre-recording of MundoFox's primetime game show, "Minuto Para Ganar." Following makeovers provided complimentary by "Minuto Para Ganar", IRPS patients watched as the Posadas competed in minute-long challenges using conventional objects in unconventional ways for a chance to win \$100,000 for charity—and won! Jorge and Laura kindly

chose to donate their \$10,000 winnings to the NFFR. In honor of their son, Jorge and Laura founded the former Jorge Posada Foundation aimed to raise awareness of craniosynostosis and provide families and affected children with emotional support and financial assistance.

Thank you, Posada family, for such a great day spent with IRPS families and the generous contribution to the NFFR's support of the IRPS.



Flying in for an appointment? Thanks to the Southwest Airlines Medical Transportation Grant Program, we are able to provide complimentary, roundtrip tickets to our families. To make medical travel arrangements, contact Carolyn at 212-263-6656.

The Pendletons from Grove City, Ohio enjoy family time on the NFFR playground thanks to their Southwest tickets.

The NFFR Family Apartment is available on a sliding scale for out-of-town families whose children are receiving care at the Institute.

For accommodation arrangements, contact Kir at kir@nffr.org or 212-263-6656.

Photo by Mary Spano



Maggie
"I
am
beautiful"

Photo by Tabitha Robinson Sherrell

Patient Spotlight

How has your craniofacial difference defined you?

Society perceives people who look different on the outside as strange. Consequently, because of my craniofacial difference, my self-image was initially affected in a negative way. Having a craniofacial difference has brought both good and bad experiences, all of which have enabled me to define my own perspective regarding what I was born with and how I see myself.

As a child, I can remember the stares from strangers and whispers as I walked by, but I knew I was proud of what I looked like. I was proud of everything I had gone through; I had experienced things at such a young age that children and adults couldn't understand. I learned that if I wanted people to understand who I was, I would have to tell them. If I wanted people to look past my differences, I would first have to look past them and stand up for myself. To me, doctor's visits were and still are fun, and going into surgery was an adventure that my parents assured me would be over before I knew it. My nurses and doctors were and are my friends and family. I realize that within my experience of having hemi-facial microsomia, I have learned to love everything about who I am and where I have come from. My disorder cannot define me; I can only define myself. I am different, I am unique, I am beautiful and I am strong. I have learned this through my experience of being born with a craniofacial difference.

I have the courage to try new things, the strength to empower others to do so as well and the knowledge to help those who may not understand what a facial difference is to understand.

In what ways has the NFFR/IRPS helped you emotionally and psychologically?

The NFFR/IRPS have been like family to me. I know everyone there truly cares about me. The NFFR/IRPS staff always offer a listening ear and words of encouragement to guide in any troubles or concerns I may be having. Over the years, I have participated in many of the events held by the NFFR. At these events not only do I get a sense of love and camaraderie from everyone, but I gain lifelong friendships with other adults and children with facial differences and build a special bond that truly cannot be described. It's an amazing feeling to know that there are so many other people going through the same things I have endured. I can talk to these friends and explain personal situations to them that someone who hasn't experienced what it is like to have a facial difference can't understand. It's an amazing feeling to feel loved by all of these people who have cared for you and taken care of you for so long.

We are deeply grateful for your interest in supporting the NFFR and the work we do. Your investment will enable us to make a difference in the lives of children with a facial difference. Thank you.

WHY GIVE?



When you give to the NFFR, you are part of a special group which allows the Institute of Reconstructive Plastic Surgery to take on some of society's most complicated medical cases. Your gift will allow the IRPS and the NFFR to continue to serve as leading catalysts for positive change for generations to come.



Donor Spotlight

why
we
give

Two Wonderful Samaritans Meet Genny

Photo: Nick O' Neill, Genny, Mary Valiante

Back in 1990 we found ourselves in the happy position of being able to increase our charitable donations. We both felt that the world can be a harsh place for beautiful children who by birth or event have physical appearances that differ from the norm. When we researched the NFFR and the work it was doing, we felt it fit perfectly with our desire to support the work of facial reconstruction. After that first year we continued to support NFFR with annual contributions. In 2001 we were introduced to a young girl from Peru (Genny) who needed extensive reconstructive facial surgery for injuries sustained in an accident when she was an infant. Her first surgery, sponsored by the Rotary

Club, was performed in Camden, New Jersey. Following that we felt Genny would benefit from additional surgery. In 2005, we reached out to NFFR for assistance. NFFR opened their arms to us and offered Genny amazing financial support, guidance and comfort over the next several years and several surgeries. Genny is now a beautiful young woman back at home in her last year of study for a Medical Therapist Degree in Peru. NFFR helped to give Genny a face, a confidence and a dream. Everyone involved with NFFR knows how life-changing their help can be and Genny and we will be forever grateful for the gift we received. - Nick O'Neill and Mary Valiante

GET CREATIVE!

Holiday Giving! Rally the troops around various holidays to sell items with that holiday's theme. On Valentine's Day, sell roses or handmade cards or for Easter, sell homemade Easter baskets. People will feel good about helping out a cause while meeting their holiday needs.

Get The Kiddies Involved! Kids are always looking to get involved. Hold a Teddy Bear Picnic, A Kids Day Out, a Lemonade Sale or teach kids dancing, modeling, acting, arts activities etc.

Get Hip to Affinity Group Fundraising! Volunteer for our Young Professional Board and help create amazing events including our upcoming Super Bowl party on January 30th.

Host a Garage Sale! They say that one man's stuff is another man's treasure. Sell your old stuff, get the entire neighborhood involved, and donate the proceeds to the NFFR.

Competitions Rule! Everyone has a competitive spirit. Consider hosting a competitive event like a Wii or X Box challenge for prizes. Each entrant pays a fee to compete for bragging rights and other prizes.

Birthday Pledges and Wedding Gifts! Ask for donations to the NFFR instead of birthday or wedding gifts.

HOW TO GIVE

To make your gift via credit card today, please visit <http://www.nffr.org/Donate.html>

If you would like to make your donation via check, please make it payable to the NFFR and mail to:

333 East 30th Street, Lobby Unit
New York, NY 10016

If you have any questions about making your gift, call Erin Johnson, Director of Development at 212.263.6656 or e-mail Erin at erin@nffr.org



races for faces

Photos by Mary Spano

We are thrilled to announce that the NFFR raised \$125,000 on Saturday, July 20th, 2013!



DISCO *for* MEDICINE

The NFFR's Annual Spring Gala

WE ARE EXCITED TO SHARE
THAT WE RAISED \$845,000
AT GOTHAM HALL ON APRIL 25TH, 2013





Photo by Mary Spano

THANK YOU, WHITNEY FOR 14 YEARS OF OUTSTANDING LEADERSHIP

It is with heartfelt gratitude that we honor Whitney Burnett for her 14 years as NFFR's Executive Director. Since joining the NFFR in 1999, Whitney has been a steadfast champion of NFFR's mission of changing faces and transforming lives. Simply put, the NFFR would not stand as strong as it does today without Whitney Burnett, and we look forward to her continued involvement as a trusted advisor.

WORDS ON WHITNEY

**Dr. Joseph G. McCarthy, Lawrence D. Bell
Professor of Plastic Surgery:**

Whitney and I began working together in 1999. I immediately recognized her optimism, can-do attitude, and spirit of goodwill. She has always believed in the mission of the NFFR, the plight of patients with facial difference, and has always been committed to making it possible that they receive optimal, multidisciplinary care regardless of their ability to pay. At the same time, she recognized that there was also a bigger picture: the associated role of education and research. In 2005, at the time of the 50th anniversary of the Institute, we knew that the Institute was woefully inadequate in space and there was no single space available at the NYU Langone Medical Center to accommodate our total needs. It was at that time that we developed the plan for a Capital Campaign. From the beginning, Whitney, ever cheerful, took the ball and ran with it. Over the years, she also led efforts to provide funds for research in areas related to facial difference, and her fundraising successes have resulted in improved educational programs at the Institute. Whitney has left an incredible legacy, including a new spectacular Institute and a new home for the Foundation, all of which have benefited our patients and families. While Whitney has stepped down, she has left a much stronger foundation for the NFFR and the Institute as it moves forward into the next half-century.

All of us salute and thank you, Whitney!

Eileen Newman, NFFR Board President:

I met Whitney in 1999 after my granddaughter was operated on by Dr. Cutting for her cleft lip and was awaiting surgery for her palate. I became aware of the NFFR through Whitney when my late husband, Arthur, and I decided to make a holiday donation to the Orthodontic Unit. Whitney has been the one who convinced me to get involved with the NFFR. She was an excellent Executive Director who brought in numerous grants to our organization and was closely involved with the IRPS and our board. I will miss her beautiful smile.

John Gordon, Chairman of the NFFR Board:

Whitney comprehensively transformed the NFFR for the better during her tenure as Executive Director. Thanks to her energy, passion and perpetual allergy to complacency, she materially raised the organization's visibility and expanded its circle of donors. At the same time, she represented the NFFR with professionalism, grace and an infectious positive attitude, and she was hugely helpful in maintaining a very close relationship between the organization and the IRPS. The NFFR will forever be indebted to her. As a final matter, she is simply a fabulous person.

Jane Gould, NFFR Board Member; Chair of the Executive Committee:

Whitney has always been the welcoming face and personification of the NFFR's goodwill and positive attitude. Without Whitney's perseverance, the IRPS would not have its new, state of the art facility and the NFFR would not have its special offices near the Institute. Without her determination, unique surgery such as that for professional cyclist Damian Lopez Alfonso would not have been funded. Her enthusiasm and drive encouraged the NFFR to "try harder." She succeeded. Her efforts allow the NFFR to take the next step towards enabling our children to face the world with a smile. Thank you Whitney.

Susan Friedman, NFFR Board Member:

Whitney, from my heart to yours, thank you for your devotion, hard work, and sincere love for all the children and their families. You made a difference and that is the most important thing anyone can do. The NFFR reached great heights and achievements under your watch.

Anne McGuinness, NFFR Board Member:

We thank you Whitney for being such a wonderful leader and giving both the IRPS and the NFFR such beautiful homes. Your compassion and dedication always inspired us, and we wish you well in your future endeavors.

Dan Rosenbloom, NFFR Board Member:

Whitney, the NFFR will not be the same without you at the helm. You have been a fantastic leader and will be very much missed. Wishing you all the best.

Carolyn Spector, NFFR Executive Director:

I am incredibly honored that Whitney has passed the torch on to me to carry on the wonderful work that she accomplished over the past fourteen years. Whitney cares very deeply about each of the patients at the IRPS and has worked tirelessly to assure funding for each and every child who needs help. I am grateful that Whitney will remain involved with the Foundation and will continue to share her wisdom with my new team and me. Whitney is an amazing lady and we hope to make her proud.



WELCOME

William S. Villafranco



The NFFR Board of Trustees is excited to welcome William S. Villafranco as its newest member. Bill is founder of Villafranco Wealth Management, an independently owned investment boutique. Bill brings over 25 years of experience in finance and held positions at Chase Manhattan Bank, Bessemer Trust Company, Credit Suisse & Alpha Investment Management, Inc. before founding his own firm. Mr. Villafranco received an EPIC (Estate Planning and Investment Counsel) award from Trust and Estates magazine honoring his approach to combining the investment management discipline with estate planning.

A longtime advocate of charitable giving, in 2003 Bill founded the Footprints in the Sand Foundation, a 501 (c) 3 non-profit organization dedicated to helping NY & NJ families who have been affected by a recent tragedy. In 2010 Bill became the co-trustee of the Virginia B. Toulmin Foundation, a 501 (c) 3 non-profit organization dedicated to improving the quality of life and improving conditions for children and their families in selected communities across the United States.

thank YOU

Rich Jennings



The NFFR bids a fond farewell to Board of Trustee, Rich Jennings. Rich has served on the NFFR Board since 1986 and was appointed to serve as Treasurer in 2009. We would like to thank Rich for his steadfast support and his financial leadership. The entire Board will miss him and wish him well.



Our Deepest Sympathy

RAWLEIGH WARNER

With the passing of Rawleigh Warner, the NFFR and the Institute of Reconstructive Plastic Surgery have lost a true friend and supporter. Rawleigh and his wife, Mary Ann, a long-term NFFR Board member, generously supported the NFFR programs during a period of challenging financial times and ever-increasing patient needs. They have been active members of the NFFR leadership team for over 30 years.

All of us will remember Rawleigh as a gentleman, ever gracious in demeanor, and caring for our patients and their families. With the respect which he enjoyed in the corporate world, he was also able on many occasions to secure additional grant support for the NFFR programs.

His grand-daughter, Emily Parsons, was also a member of the NFFR staff for several years.

All of us at the NFFR, as well as the staff and patients at the Institute of Reconstructive Plastic Surgery at the NYU Langone Medical Center, send our condolences to Mary Ann, his daughters, and extended family. I am sure that they have warm and loving memories of this outstanding and caring man - - memories that will sustain them during these difficult times.

Joseph G. McCarthy, M.D.

Max Adler

On May 29, 2013, the NFFR and IRPS unveiled a new plaque in commemoration of the life of Max Adler and the immense joy he brought to the people of the Institute. Among those in attendance were Max's parents, Jerome and Beth, brother Ben, and the Craniofacial Surgery and Orthodontics teams that had the privilege of caring for Max for over 21 years. Max's incomparable courage and unwavering spirit will forever be engraved in the hearts of his special team and walls of IRPS.

Photo by Mary Spano





National Foundation
for Facial Reconstruction
333 East 30th Street, Lobby Unit
New York, NY 10016
Nffr.org



JOIN US ON SOCIAL MEDIA!

Facebook: <https://www.facebook.com/NationalFoundationforFacialReconstruction>

Twitter: <https://twitter.com/theNFFR>

Tumblr: www.thenffr.tumblr.com

WHY WE LOVE WHAT WE DO

Dear NFFR,
I love what you do. I know what it feels like to
be made fun of because of my likes and being
made fun of for looks is more serious and is cruel
Your work gives children the right to feel
like other people

Zach Feldman

upcoming events

Saks Fifth Avenue Shopping Extravaganza November 2013 (Stay tuned)
Family Holiday Party December 1, 2013
Young Professional Board Super Bowl Kick-off Party @ Greenwich Village
Country Club January 30, 2014
Spring Gala @ the Central Park Zoo May 15, 2014
3rd Annual Races For Faces September 2014 (Stay tuned)

MYFACE

THE NEW NFFR MAGAZINE

Board of Directors & Honorary Trustees

President

Eileen Newman

Chairman

John R. Gordon

Vice Presidents

Yoron Cohen

Frederick M. Friedman

Jane M. Gould

Antoinette Guerrini-Maraldi

Phebe Miller Olcay, Esq.

Barbara H. Zuckerberg

Secretary

Clare Thomas

Treasurer

Richard B. Jennings

Trustees

Robert E. Bochat

Jeremiah M. Bogert

Court Baldwin Cutting, MD

Susan Friedman

Alexes Hazen, MD

Joseph G. McCarthy

Anne McGuinness

Wilson S. Neely, Esq.

Laura Posada

Daniel Rosenbloom

David A. Staffenberg

William Villafranco

John C. Wohlstetter

Honorary Chairman

J. Peter Hoguet

Honorary Trustees

Brownlee O. Currey

Jerome T. Falk

Scott Greenstein

Bruce Morrow

Mrs. H. Virgil Sherrill

Mrs. Rawleigh Warner, Jr.

Roger S. Weber